

Year 7 Textiles Homework

Lesson one:

Design a leaflet for KS3.

The leaflet must have the following: 10 different textiles products with images and explanations of processes used to make the product. Title in a creative manner and your name as the author.

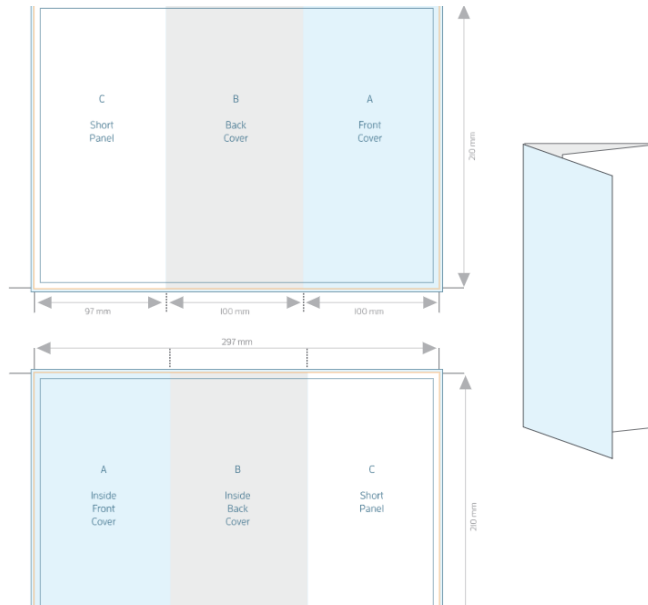

Lesson two:

Research and present a page on the textiles artists Debbie Smyth, AO1, remember to get the following information and at least 4 images of her work:

DOB, Nationality, influences, materials used and your own opinion of her work and how you could use her ideas in your own work. (see example below)



Lesson three:

Present creatively a list of all the soft furnishings in your home that have stitching on them somewhere. Take a photograph or collect images from the internet. Describe the items and say whether you think the stitches were created by hand or machine.

Lesson four:

Design a cushion demonstrating the use of at least 2 types of embellishment and one type of hand stitching based on the theme nature, linking to a textile artist.

Lesson five:

Research how natural and manmade fabrics are produced. Use images and information to create a table/ chart. Also research fabric dyes both natural and chemical.

Lesson six:

Design a bag for life for a shop of your choice, include applique. Add a paragraph on the advantages of using a bag for life rather than a plastic one.

Lesson seven:

Create a poster on the parts of the sewing machine, use the template below:

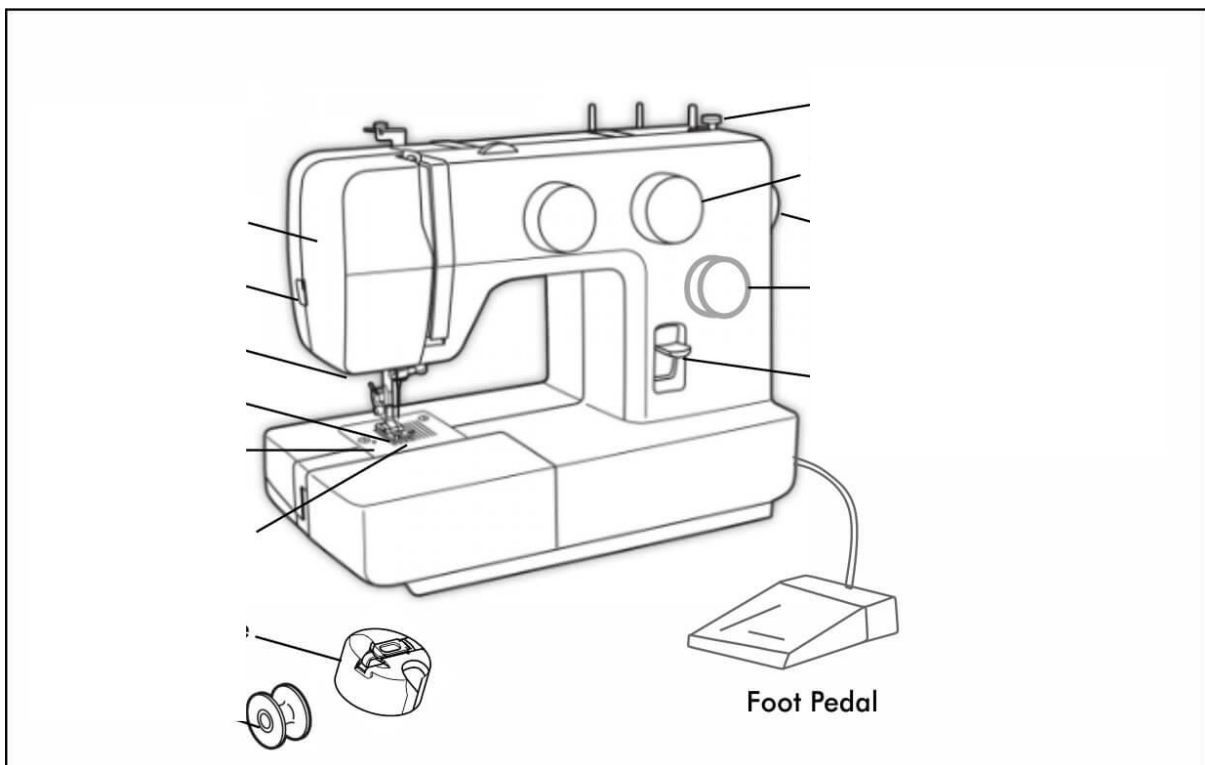

Then create a poster on ways textiles can be recycled look at the fashion designed Zero waste Daniel

Lesson 8:

Create a step by step guild on how to thread and use a sewing machine, include images, and health and safety points. You could create a small video clip instead of a 2D piece.